



Gold City[®]

Elettronica

Migliorare la qualità del Lavoro, per migliorare la qualità della Vita

B30001

Via Rovereto, 37/M -36030 Costabissara (VI) -Tel./Fax.0444-971690 - www.gold-city.it email: info@gold-city.it

AMPERMINUTEMETER WITH REGISTER, PARTIAL CLICK METER AND AMPEROMETER

(re108 08/10/08)



HARDWARE FEATURES:

- Container: Self extinguishing insulating material N185 noryl. Dimensions 48x96DIN43700
- Display: 7 section display with 6 figures and signs
- Keyboard: Thermoformed with antiscratch film, made of polyester insulating material
The keys are guaranteed for 1.000.000 working schedules. Realization power 250gr; run 0,4mm
- Terminal board: Extractable and polarized with supervision certificate IMQ n.ED622 in conformity with IEC998-1(1990) and IEC 998-2-1 (1990).
Working Temperature -40⁰C +110⁰C ; cat.climatica 40/11021 Sec.IEC
- Power: 24/110/220 Vac to be specified in the order
Possible variations +/- 10% of the nominal voltage. Consumption 5,5Watt
- Transformer: 7VA Soaked with 3000 Volt insulating voltage, built in conformity with the laws CEI 14-6 and VDE 0551
- Memory: Flash
- Microprocessor: Cypress
- Inputs: Optoinsulated at maximum 2500Volt ON/OFF 24Vdc. Maximum frequency 20Hz (software filter)
- Outputs: Optoinsulated at maximum 2500 Volt ON/OFF 40V. AC-DC. Maximum consumption: 0,07Ampere
- CE Electromagnetic Compatibility (EMC) CEI 50081-1 e CEI 50082-2

SOFTWARE FEATURES:

This instrument has an analogical input 0-60mVolt which is converted into a frequency signal proportional to the input voltage. The frequency thus generated increases the instrument meters. The impulses which have been counted are converted into a measuring unit useful to the user by a frequency divider. Sensitivity of the input converter: 0,1 millivolt. The first output signals continually the working of the schedule which has been set in the instrument; the second output signals propulsively the consumption; this can be used in automatic proportioning devices regulating the intervention time. The partial click meter in UP and DOWN, the total click meter, the power supplied and the input/output diagnostic are visualized on the display. This instrument can also be used as analogical display with a scale which varies from 60mVolt to 15 Volt (to be specified in the order).

CONNECTIONS

ON-OFF INPUTS:

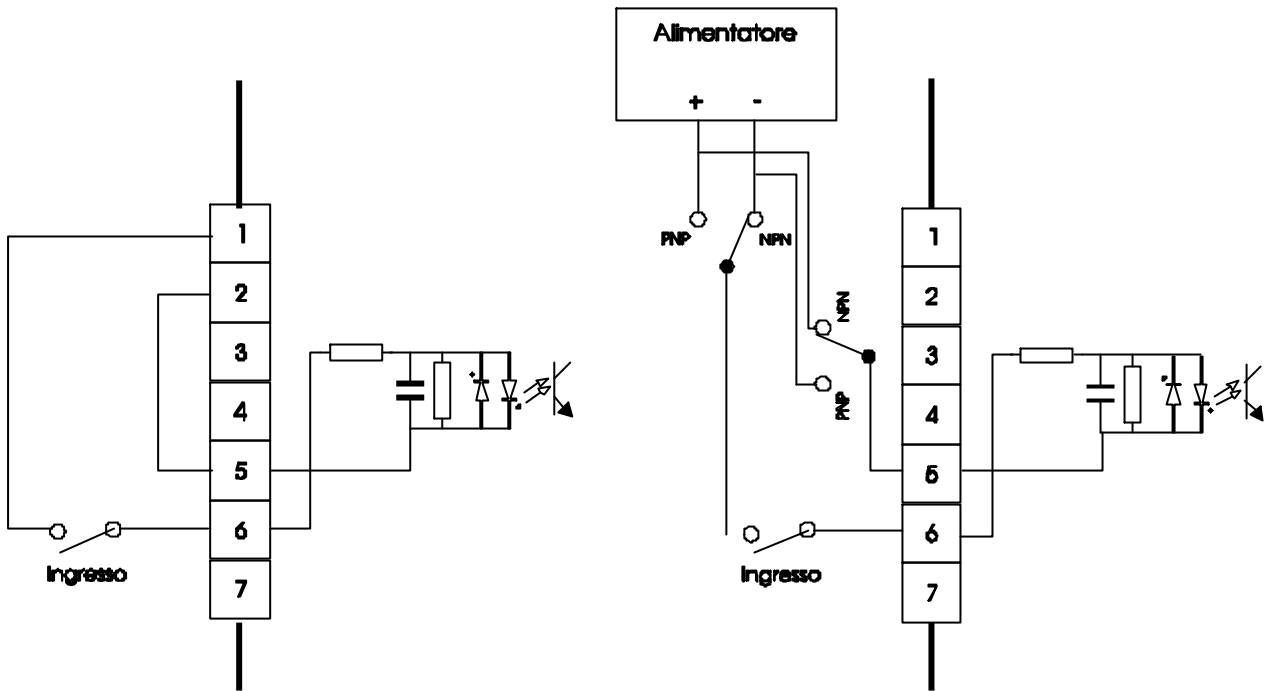

The inputs can be type NPN or type PNP, according to the polarization of the connecting terminal number 5.

Electrical features:

Maximum voltage 24Vcc

Impedance 1k2 ohm

Maximum frequency: 20Hz with a 50 mseconds input filter in the software

OUTPUTS:

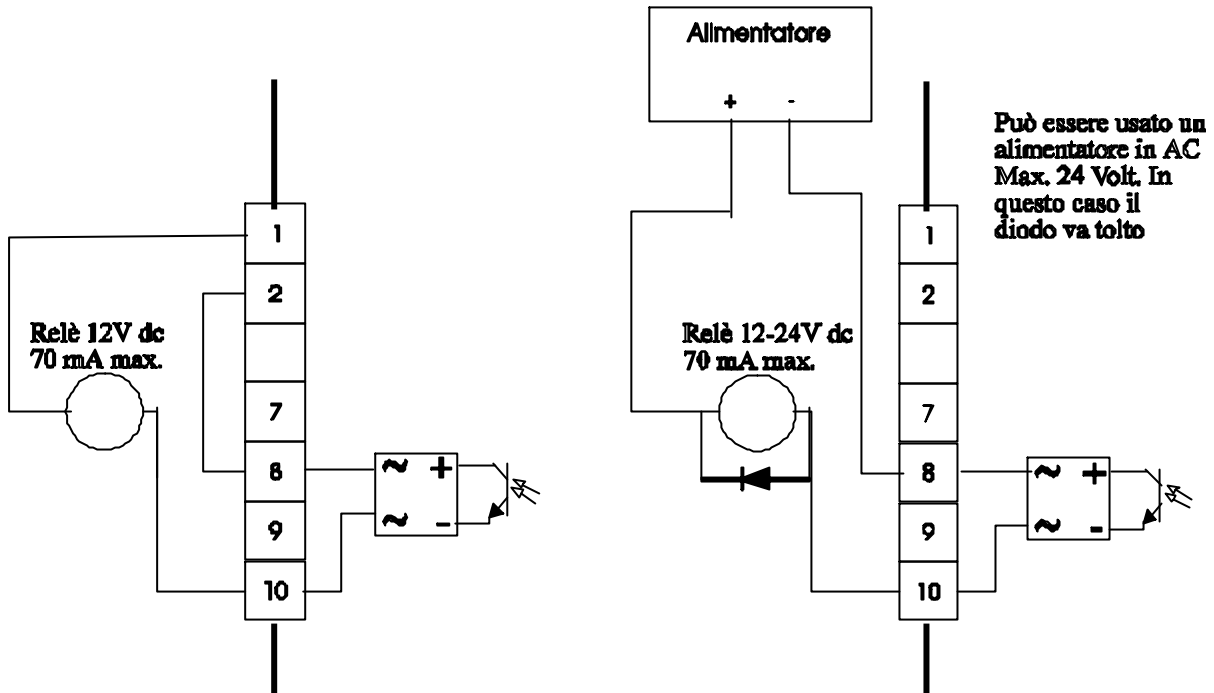



Electrical features:
 Maximum voltage 40Vac or dc
 Maximum current 0,070 Ampere
 Maximum frequency: 100hz

THE KEYBOARD

Keys	Description of their working
	If pressed together with the ENTER + PASSWORD keys, it gives access to the SET-UP parameters During the data input operation, it moves the figure selection rightwards If pressed together with the UP arrow key, it allows to programme the out time (U2) and U1 whit At =2 If connected and pressed for 1 second, it clears the result register
	During the data input operation, it increases impulsively or continually the selected figure (the flashing one) If pressed during the normal working, it visualizes the windows on the display If pressed together with the RIGHT arrow key, it allows to programme the out time (U2) and U1 whit At =2 When pressed for 2 seconds, it visualizes the input and the output situation
	During the data input operation, it clears the visualized datum If pressed impulsively, it clears the partial meter, starts the U1 output, allows the calculation of the partial meter
	If pressed together with the RIGHT arrow key + PASSWORD, it gives access to the SET-UP parameters It confirms the data input operation When pressed, it allows to programme the pre-selection of the partial meter

SET-UP

To have access to the set-up, press together the  **Enter** key and the  key; after 2 seconds, you will have the writing S **000** on the display. Write 123 with the Right Arrow key and the Up Arrow key; then, confirm with .

Parameter	Display	Description	Limits
Decimal figures of the click meter and its pre-selection	c 0	It indicates the number of decimal figures you want to have visualized after the decimal point	0-3
Visualization of the decimal figures	A 0	It indicates the number of decimal figures you want to have visualized after the decimal point	0-3
Maximum visualization (ampere)	n999999	It indicates the value of amperes that the instrument visualizes at the maximum frequency. Putting zero, the visualization is not connected	0-999999
Average read-out in ampere visualization	i A 99	It indicates for how many reads-out the value to be visualized gets calculated (speedometer). The bigger the read-out number, the slower the updating time of the value	0-99
Partial click meter connection	At 0	0= The partial click meter unconnected 1= The partial click meter connected (it is possible to clear it with I2=ON or with the CLEAR key impulsively) 2= The partial click meter connected end set timer U1	0-2
Result register increase	i t 0	0= The result register is always connected for the calculation 1= The result register is connected for the calculation only if U1=ON 2= The result register is not connected	0-2
Result register reset connection with the Right Arrow key	ct 0	0= The right arrow key is connected 1= The right arrow key is not connected	0-1
Partial click meter connection in down position	cS 0	0= The partial click meter in down position is not connected 1= The partial click meter in down position is connected	0-1
Configuration I2	I 2 0	0= The input is not used 1= The input serves as amperminutemeter connection 2= The input serves to start the right arrow key (it clears the result register) 3= The input set the partial amperminutemeter whith TIMER	0-3
Partial click meter working	r P 0	0= when switching on, the partial click meter gets cleared (it is put to zero) 1= when switching on, the partial click meter value is the same as the value memorized at the switching off; to make it start again, press the CLEAR key 2= when switching on, the partial click meter value is the same as the value memorized at the switching off and is always connected 3= Equal r P =2 whit automatic clear partial click meter at preset value	0-2
Impulser divider	d999999	It is the impulser divider number	1-999999

INPUTS

Terminal number	Input	Description of their working
4	I1	60mV..Analogical input 0-60mV to be connected to the shunt with a shield cable
6	I2	Amperminutemeter connection (ON). When disconnected (OFF), it stops the working of the click meter but keeps the visualization (if connected); it disconnects U1 and the CLEAR key. The input I3 read-out is connected. The working of this input can be left out from the set-up parameter I 2=0 . With I 2=2 , the working of I2 is equal to the right arrow key.
7	I3	Click meter reset. If connected impulsively, it clears the number of the partial click meter and starts the output U1

OUTPUTS

Terminal number	Outputs	Description of their working
9	U1	Reached pre-selection. It starts when the CLEAR key or the I3 input are pressed. It is disconnected when the partial click meter has reached the pre-set selection. With U1=ON, it is connected for the calculation of the partial click meter. If A t =2 (set-up) the U2 is connected for the time pre-set (t 1)
10	U2	Impulsive reached pre-selection. It is connected for the time pre-set (t 2) when the partial click meter has reached the pre-set selection. It is used in automatic proportioning devices.

Output working graph

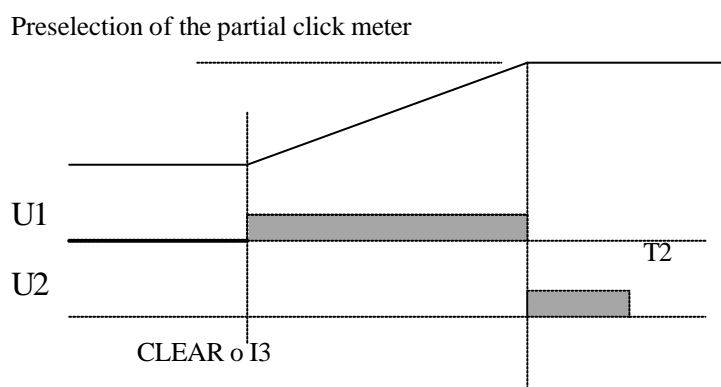

PRE-SET PROGRAMMING OF THE PARTIAL CLICK METER

To start the pre-set programming of the partial click meter, do as follows:



Press the  key; the display visualizes:

P 12345

Using the right arrow key and the up arrow key, the user can select the figure which has to be put in (from

999999 to 1); when confirming with the  key, the display shows again the main visualization.

U2 TIMER CONNECTION PROGRAMMING

To start the programming, press the  key together with the  key; the display will visualize:

t 2 999.9

Using the right arrow key and the up arrow key, the user can select the figure which has to be put in (from 999.0 to 0); when confirming with the  key, the display shows again the main visualization. If **At** =2 (set-up) the display will visualize **t 1**

RESET PRODUCER

For clearing producer press the  key together with  key for 2 seconds; the display will visualize:

S 000

Write **304** with the Right Arrow key and the Up Arrow key; then, confirm with .

the display will visualize

r ESEt

Calculation Impulser divider

At the maximum power (at the end of the instrument scale), 600 clicks a second are counted, with the divider=1.

To calculate which divider to put in, do the following formula:

$$DIV = \frac{36000 \times CP}{CS \times FS}$$

where:

DIV= Divider to put in

CP= Pre-set power

FS= Power at the end of the scale (maximum shunt power)

CS= Click meter you want to get in one minute

For instance: to get 50 clicks a minute with a 200 Ampere galvanic bath and a working power equal to 75 Ampere, you will have to put the DIV value:

$$\frac{36000 \times 75}{50 \times 200} = 270$$

Note: If you want to introduce a value in relation to a click meter per hour, you will have to substitute the constant 36000 with the constant 2160000.

If you want to get one click per minute for each ampere used, refer to the following schedule which gives the values of the divider to put in in relation to the shunt installed

SHUNT	DIVIDER
10A	3600
25A	1440
50A	720
100A	360
150A	240
200A	180
250A	144
300A	120

SHUNT	DIVIDER
400A	90
500A	72
600A	60
800A	45
1000A	36
1500A	24
2000A	18
3000A	12

VISUALIZATIONS

During the normal working, the display visualizes one windows.

Pressing the  key, the display visualizes:

1 2 3 4 5 6	partial click meter	It is shown with At =1 (it gets cleared when pressing impulsively I2, or with the CLEAR key)
t 1 2 3 4 5 6	Result register	It is shown with lt =0 or lt =1 (it gets cleared by pressing for more than 1 second the right arrow key - if connected - or with l 2 =2). Note: when switching off, the calculation of the result register is saved.
U 200	Amperometer visualization	It is shown with n different from zero
d 1 2 3	partial click metre count down	It is shown with CS =1 (set-up)
1 2 3 1 2	Input/Output diagnostics	Pressing the  key for 2 seconds, the display visualizes Input/Output diagnostics. In this visualization if pressing ENTER U2 is ON for the time 2
EEEEEE	ERROR	If the datum to be visualized is out of the scale, the display will visualize the letter “e” on its place.

CONNECTIONS

Terminal number	Name	Description
1	-5V	-5 Volt 0,1 Ampere Output. It can be used to give power to transducers and input wires
2	+5V	+5 Volt 0,1 Ampere Output. It can be used to give power to transducers and input wires
3	0V	Wire of the double power +/- 5Volt and shunt positive input
4	I1	Analogical shunt input 60mVolt negative
5	P	Polarization terminal for the inputs I2 and I3 (+ NPN - PNP)
6	I2	Amperminutemeter connection
7	I3	Click meter reset
8	CU	Wire of the output polarization
9	U1	Reached pre-selection
10	U2	Reached impulsive pre-selection (for alarms and proportioning devices)
11	GND	Earthing terminal
12	VAC	Terminal to give power to the instrument
13	VAC	Terminal to give power to the instrument

ORDER CODE

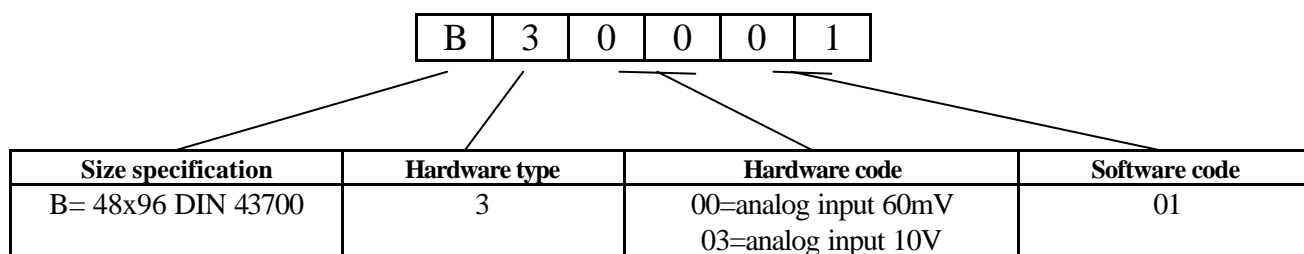

Warning: On the order, you must specify the power voltage of the instrument which can be 24-110-220 VAC

DIMENSIONS

Front pannel

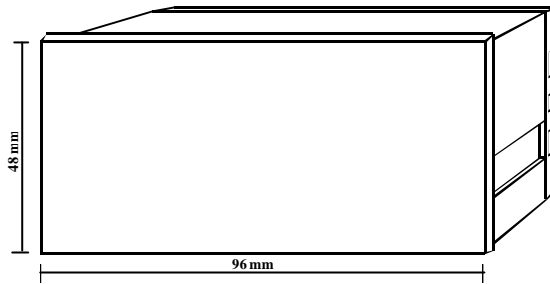

Back panel

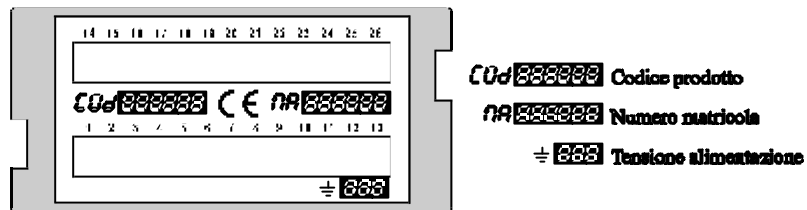

PROPRIETA' DELLE INFORMAZIONI

Questo manuale contiene informazioni di proprietà riservata. Tutti i diritti sono riservati

Questo manuale non può essere riprodotto o fotocopiato, in tutto o in parte, senza il preventivo consenso scritto della Gold City snc. L'uso di questo materiale documentale è consentito solo al cliente a cui il manuale è stato fornito come corredo dell'apparecchio, e solo per scopi di installazione, uso e manutenzione dell'apparecchio a cui il manuale si riferisce

Gold City snc dichiara che le informazioni contenute in questo manuale sono congruenti con le specifiche tecniche e di sicurezza dell'apparecchio a cui il manuale si riferisce, Il fabbricante non si assume alcuna responsabilità per danni diretti o indiretti a persone, cose o animali conseguenti all'uso improprio di questo manuale o dell'apparecchio.

Gold City snc si riserva il diritto di apportare modifiche o miglioramenti senza preavviso a questo manuale e agli apparecchi.